

JM150 shown dotted to clarify mounting position.

VIEW ON BRACKET PACK WITH CHAIN BREAK DEVICE IN NORMAL RUNNING POSITION

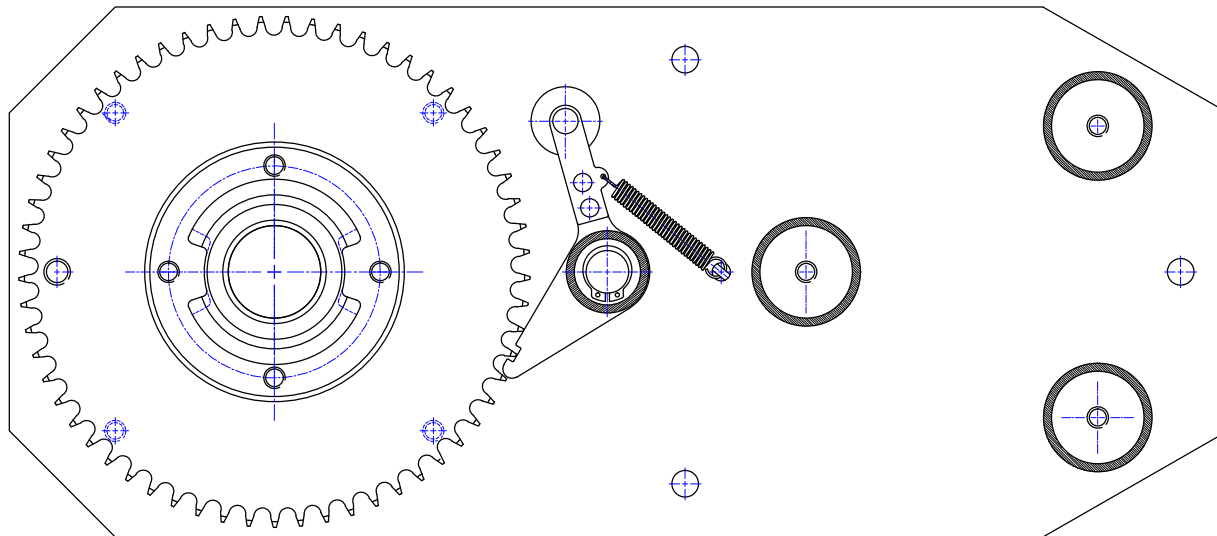

VIEW ON BRACKET PACK WITH CHAIN BREAK DEVICE ENGAGED AFTER CHAIN FAILURE.

**THIS IS A CHAIN BREAK DEVICE
IT DOES NOT PROTECT AGAINST
SINGLE
COMPONENT FAILURE
A SEPARATE ANTI DROP DEVICE
MUST BE FITTED**

This drawing is the property of ELLARD LTD, it may not be reproduced without the written authorization of Ellard Limited. All intellectual property rights are expressly reserved



Roundthorne Industrial Estate
Ellard House, Floats Road
Wythenshawe, Manchester
M23 9WB
Tel: 0161 945 4561, e-mail: technical@ellard.co.uk

Title

**GENERAL ARRANGEMENT
FOR BP6 (JM150 & JM200)
(STOCK CODE 03274)**

Rev/Notes

Date 01/11/2020

Drawn by DE Chk'd by AP

Drg # BP6 - General Arr (2)