

BILL of MATERIAL			
Item	Qty	Description	Code #
1a	1	200 x 460 x 6 thick mild steel plate	
1b	3	Ø35mm dia x 4mm thick steel spacers	
1c	3	M8 x 65mm long steel stud	
1d	1	Ø50 x 82 long steel bar	
1e	1	Ø25 x 28 long steel bar	
5	1	Ø15 spring steel circlip	
6	1	Ø32 spring steel circlip	
7	1	Ø35.5 x 3 thick mild steel washer	

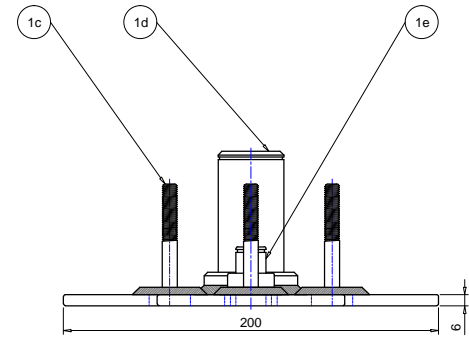

This drawing is the property of ELLARD LTD, it may not be reproduced without the written authorization of Ellard Limited. All intellectual property rights are expressly reserved

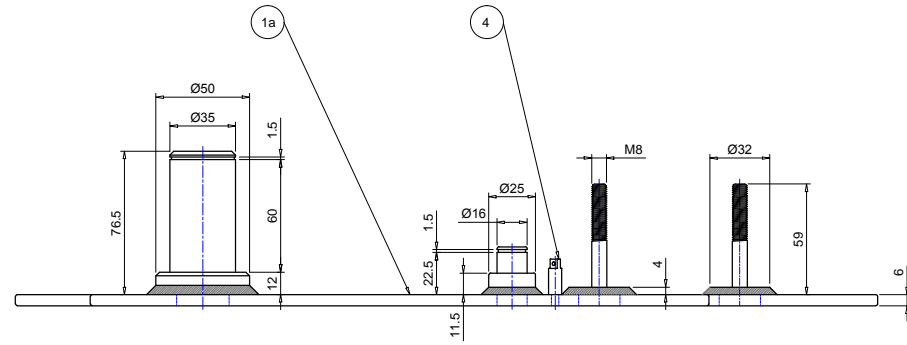
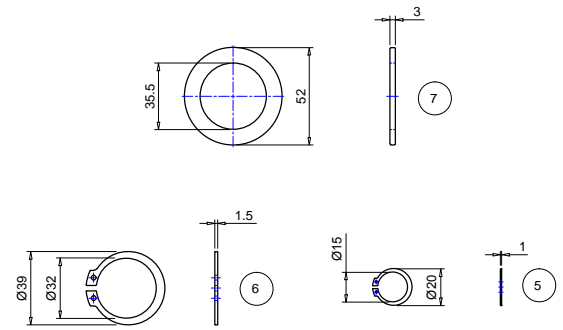

Roundthorne Industrial Estate
 Ellard House, Floats Road
 Wythenshawe, Manchester
 M23 9WB
 Tel: 0161 945 4561, e-mail: technical@ellard.co.uk

Title

GENERAL ARRANGEMENT
 FOR BP5 (JM500)
 50T PLATE WHEEL
 (STOCK CODE 03275)

Rev/Notes

Date

10/03/2022

Drawn by

DE

Chk'd by

AP

Drg #

BP5 - General Arr (3)