

ELEVATION ON BP-10B BRACKET PACK WITH JM750 (PCB MODEL)  
 SHOWN WITH THE CHAIN BREAK DEVICE IN UNACTIVATED MODE.

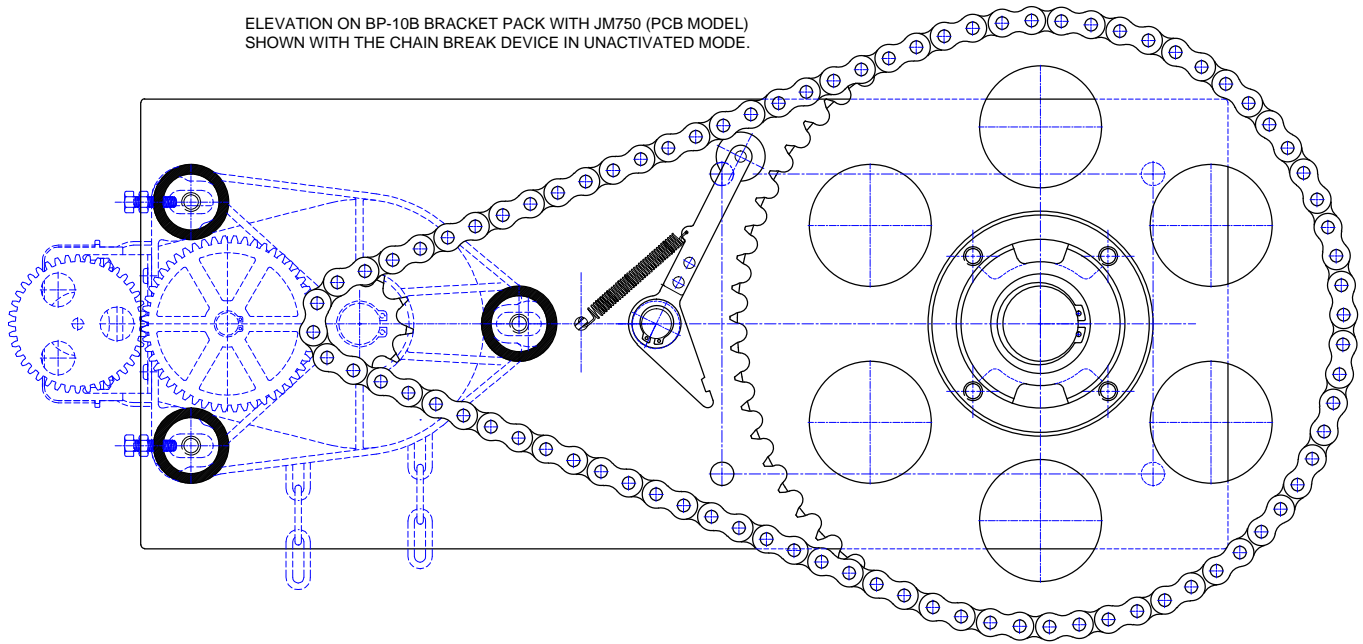

ELEVATION ON BP-10B BRACKET PACK WITH JM750 (PCB MODEL)  
 SHOWN WITH THE CHAIN BREAK DEVICE IN ACTIVATED MODE.

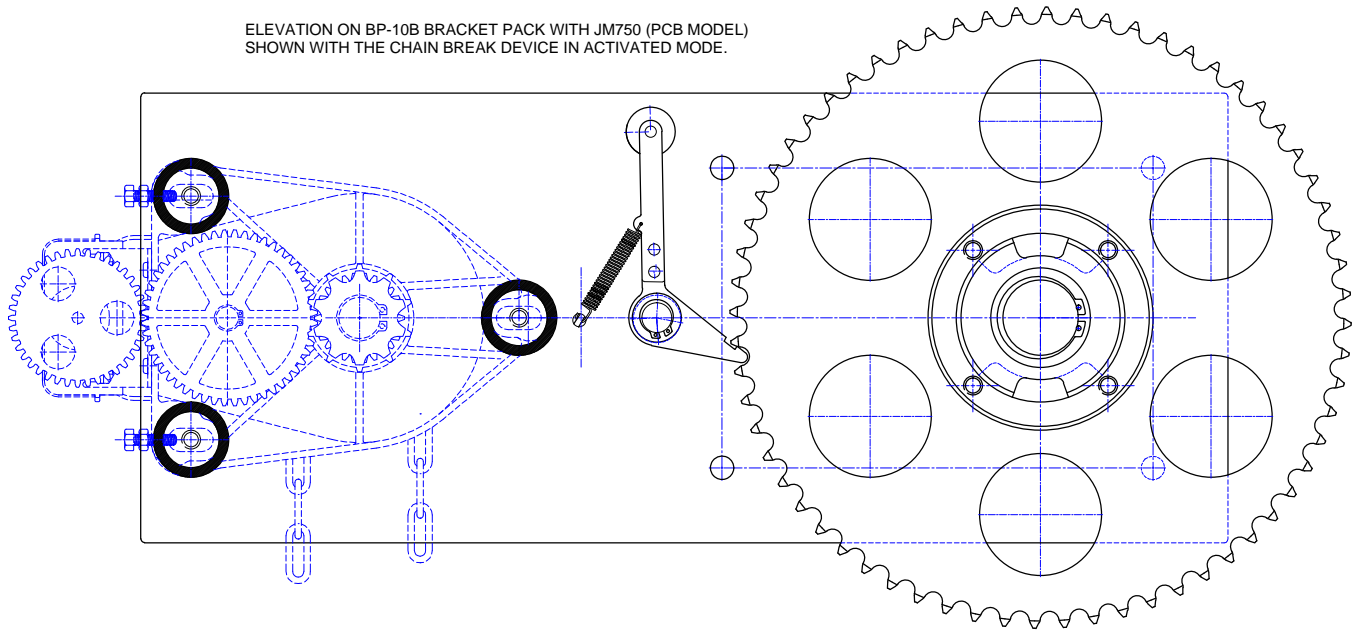

THIS IS A CHAIN BREAK DEVICE  
 IT DOES NOT PROTECT AGAINST  
 SINGLE  
 COMPONENT FAILURE  
**A SEPARATE ANTI DROP DEVICE  
 MUST BE FITTED**



Roundthorne Industrial Estate  
 Ellard House, Floats Road  
 Wythenshawe, Manchester  
 M23 9WB  
 Tel: 0161 945 4561, e-mail: technical@ellard.co.uk

*This drawing is the property of ELLARD LTD, it may not be reproduced without the written authorization of Ellard Limited. All intellectual property rights are expressly reserved*

Title

GENERAL ARRANGEMENT  
 FOR BP7 (JM750)  
 (STOCK CODE 03379)

Date 10/03/2022

Drawn by DE

Chk'd by AP

Drg # BP10B - General Arr (2)