

ELLARD

THE HOME OF AUTOMATION

DC2 Controller

(Quick Start Guide)

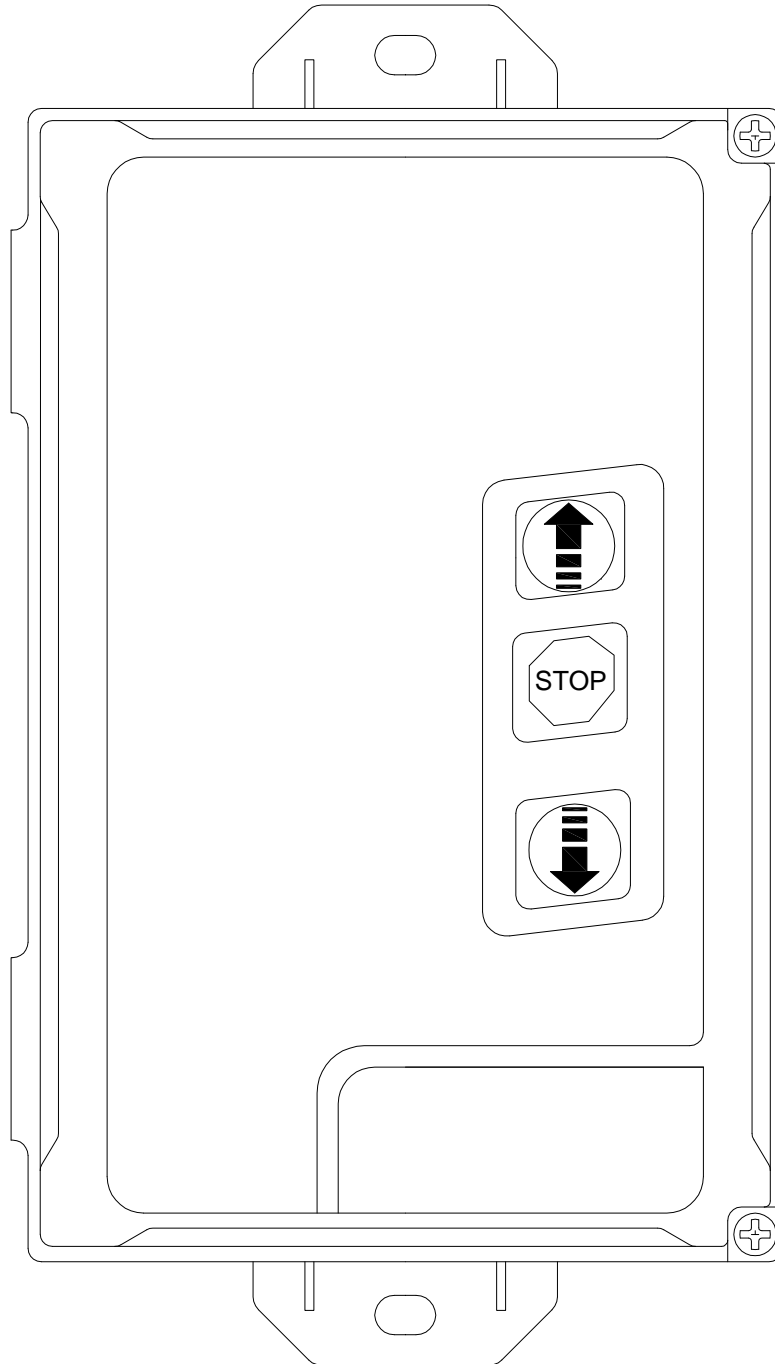

Contents

| Page | |
|------|---|
| 3 | General Layout |
| 4 | Mains Supply Connection |
| 4 | Tube Motor Connection |
| 5 | Volt Free Connection for 'JM' series operator or other controls |
| 5 | Volt Free Connection for 'F' 'W' and 'SD' series operator |
| 6 | Push Button Connection |
| 6 | Impulse Button Connection |
| 6 | Emergency Stop Button Connection |
| 7 | Optical Safety Edge Connection |
| 7 | 8.2k Resistive Safety Edge Connection |
| 7 | Pneumatic Safety Edge Connection |
| 7 | Photocell (reflective type) Connection |
| 8 | Pre-warning Light Connection |
| 8 | Red / Green Traffic Light Connection |
| 8 | 230v Courtesy Light Connection |
| 9 | Radio Receiver / Transmitter - Programming |
| 9 | Radio Receiver / Transmitter - Deleting |
| 10 | Motor Run Timer Settings |
| 10 | Closing Delay Timer Settings |
| 11 | Trouble shooting |
| 11 | Technical data |

Important Information

This booklet is a quick start guide for 'ellard' products, it is no way intended as a direct replacement of the manufacturers manual
All safety information and regulations are contained within the manufacturers manual should be veiwed before installation.

DC2 general connections

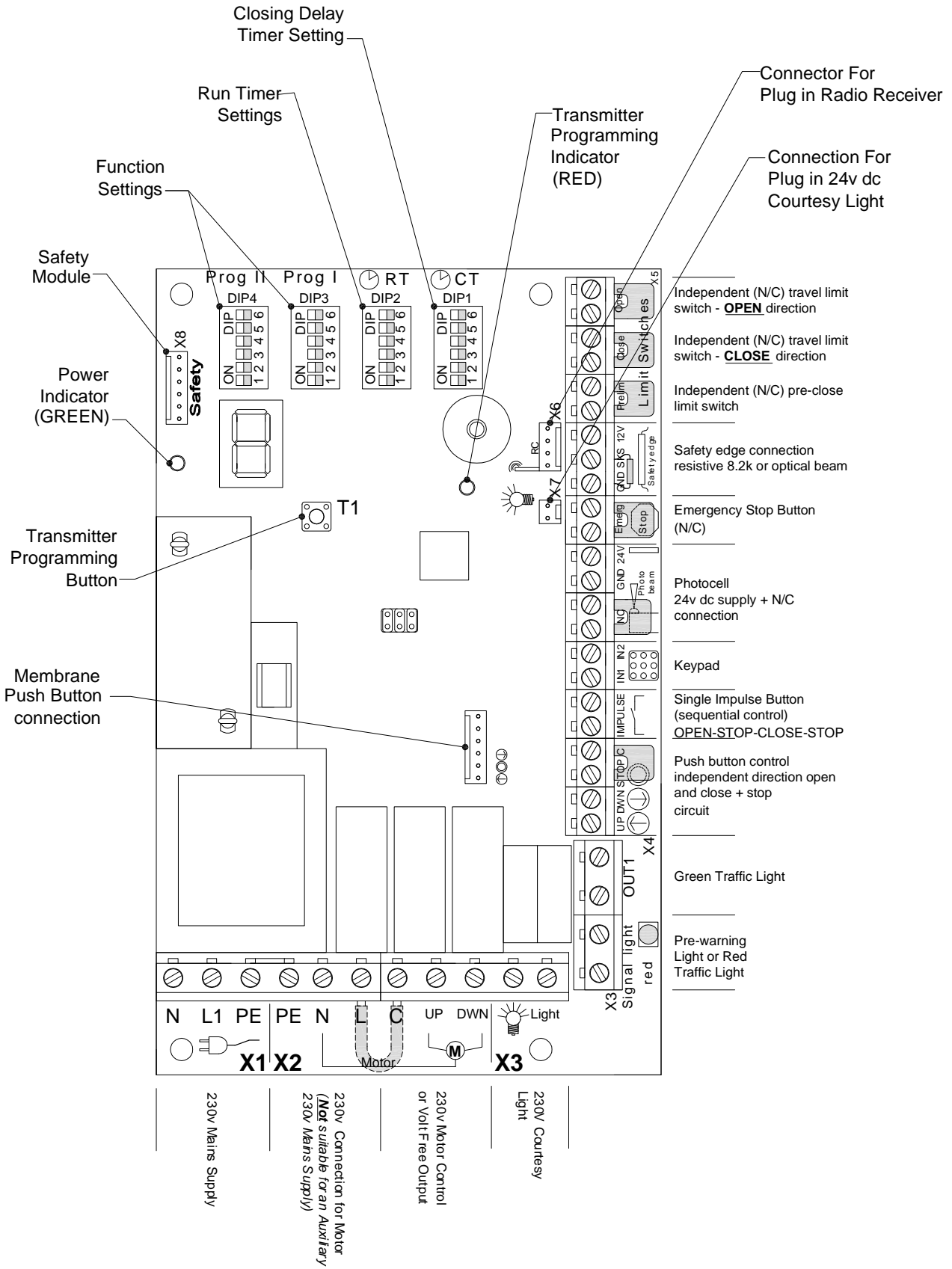

230 volt Mains Power

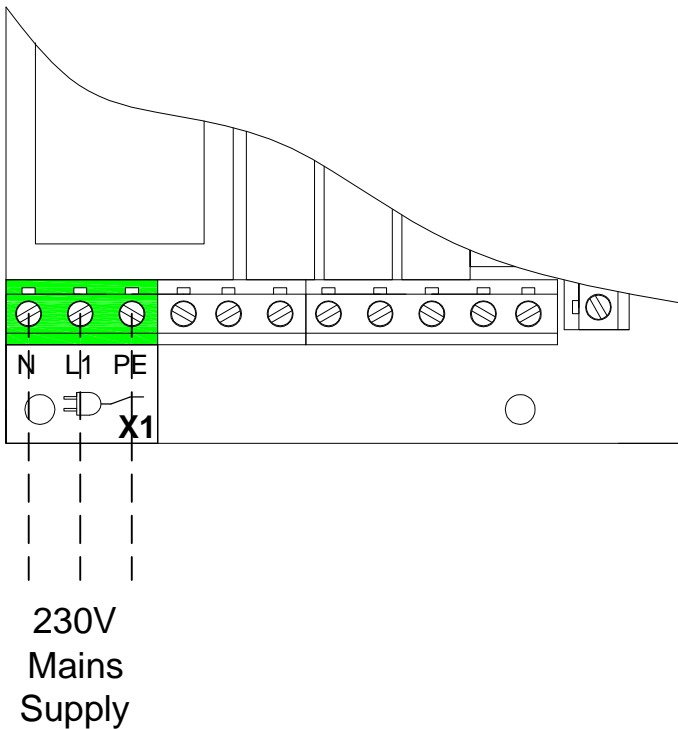

Mains Power Connection

PE = EARTH (Grn/Yel)
L1 = LIVE (Brown)
N = NEUTRAL (Blue)

Use these terminals as a direct connection for 230v (1ph) Mains supply to the DC2 Controller

This connection should be fused at 13A (max)

230v Tube Motor Connection

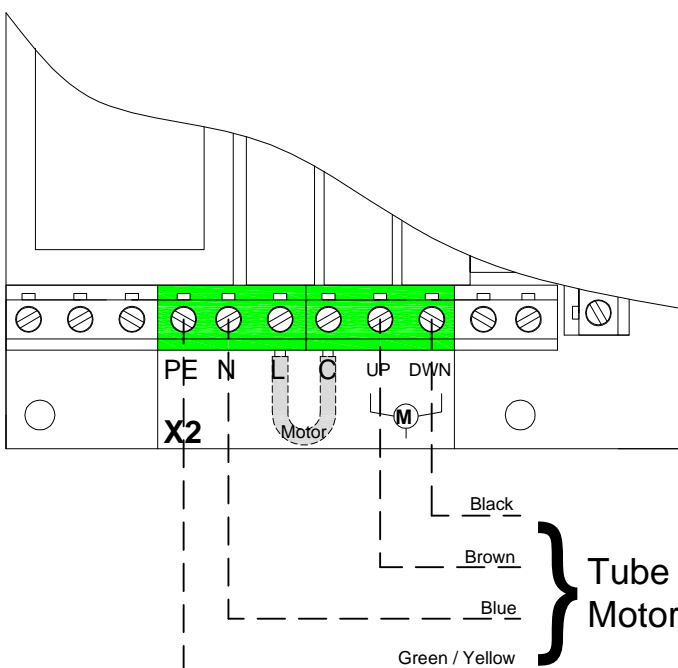

Connection to a typical 230v Tube Motor

PE = EARTH (Grn/Yel)
N = NEUTRAL (Blue)
UP = OPEN DIRECTION (Brown)
DWN = CLOSE DIRECTION (Black)

Use these terminals as a direct connection for a tube motor to the DC2 Controller

This unit still requires 230V mains power to operate

Volt free Connection for 'F' , 'W' and SD series operators

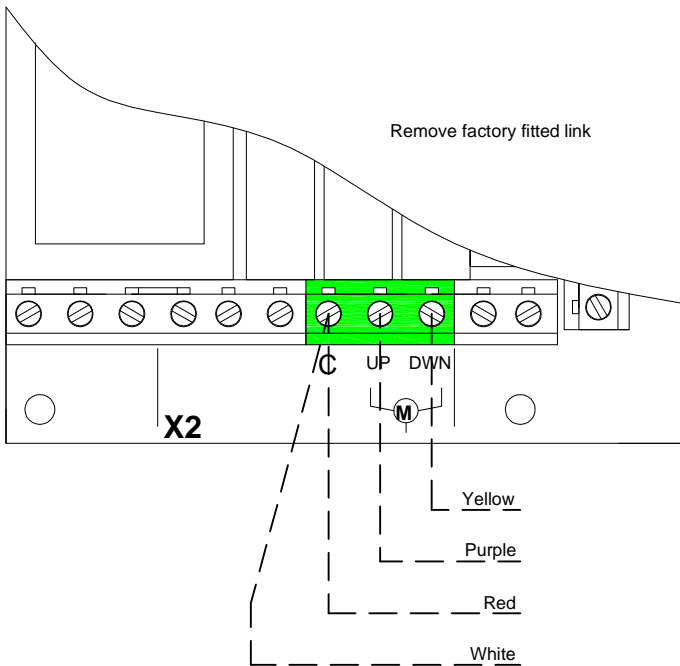

Connection

C = COMMON
 UP = OPEN DIRECTION
 DWN = CLOSE DIRECTION

Remove the existing push button station and use these terminals as a direct connection to control 'F', 'W' and 'SD' series operators

Jumper Links 'ODM' and 'CDM' must be removed from the operator PCB

****This unit still requires 230V mains power to operate****

Volt Free Connection for 'JM' series operators and other controls

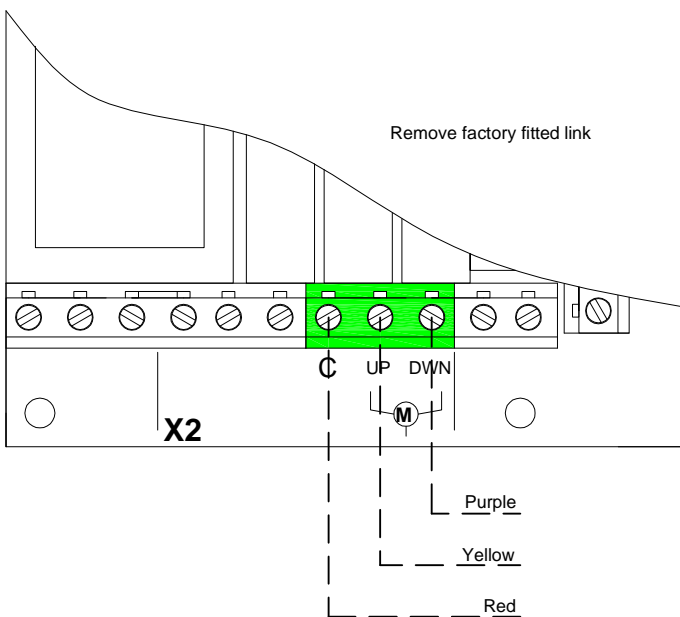

Volt Free Connection

C = COMMON
 UP = OPEN DIRECTION
 DWN = CLOSE DIRECTION

Remove the existing push button station and use these terminals as a direct connection to control 'JM' series operators or other controls

****This unit still requires 230V mains power to operate****

Remote Push Button Control
(If required)

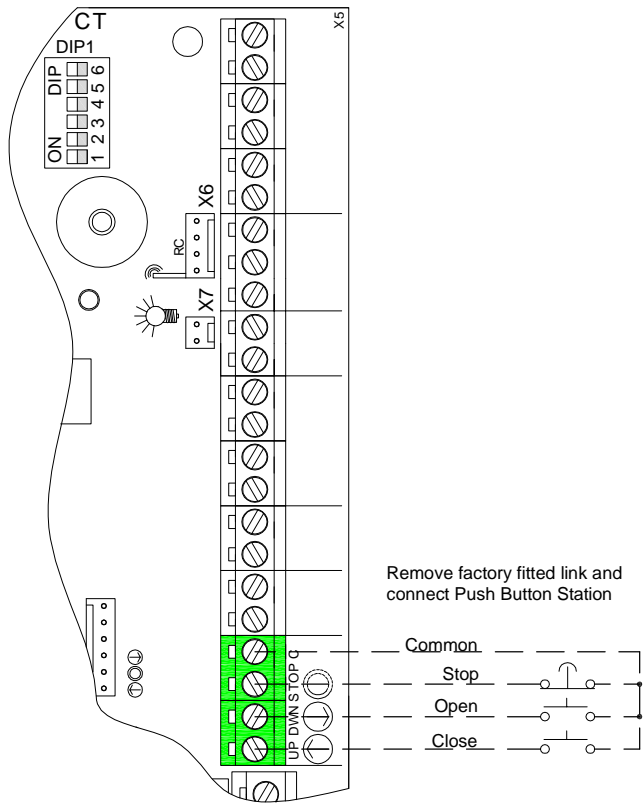

Remote Impulse Button
(If required)

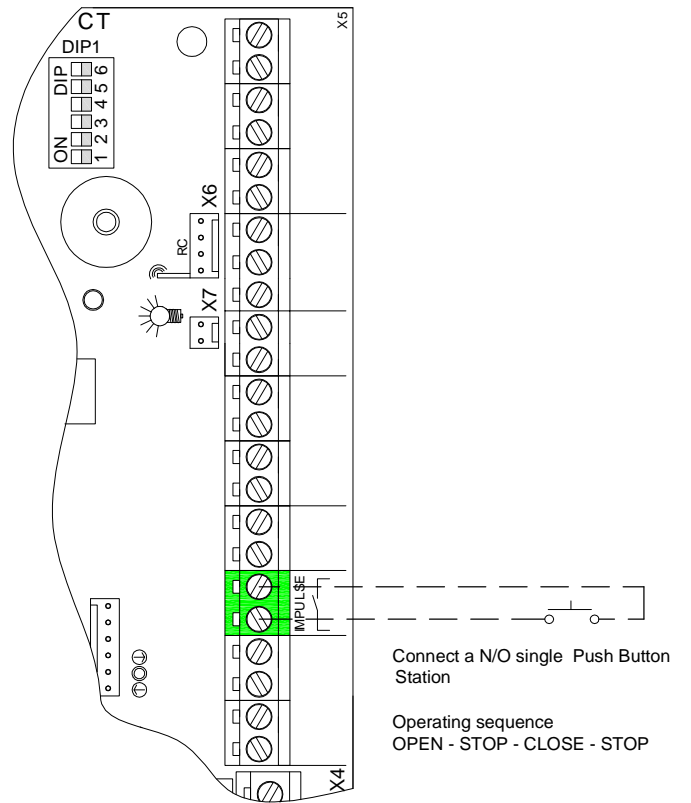

Emergency Stop Button
(If required)

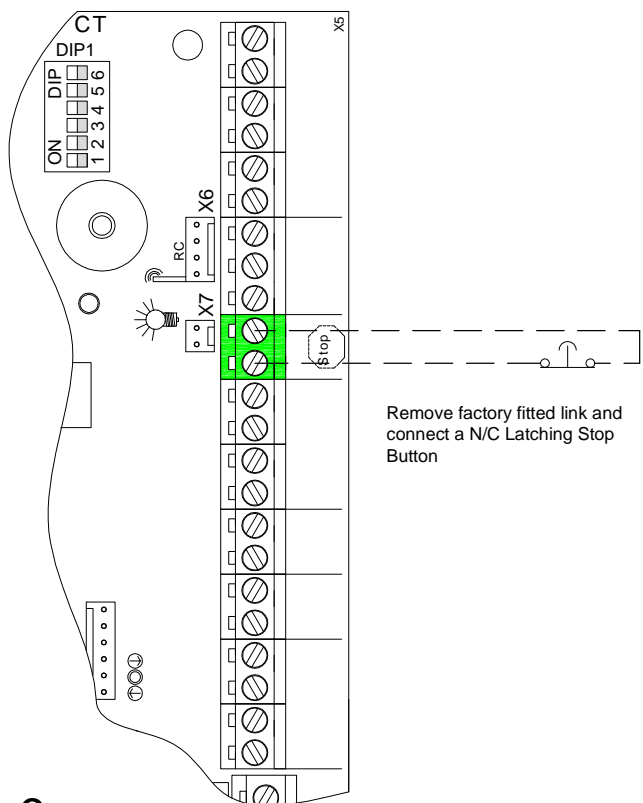

8.2k Resistive Safety Edge

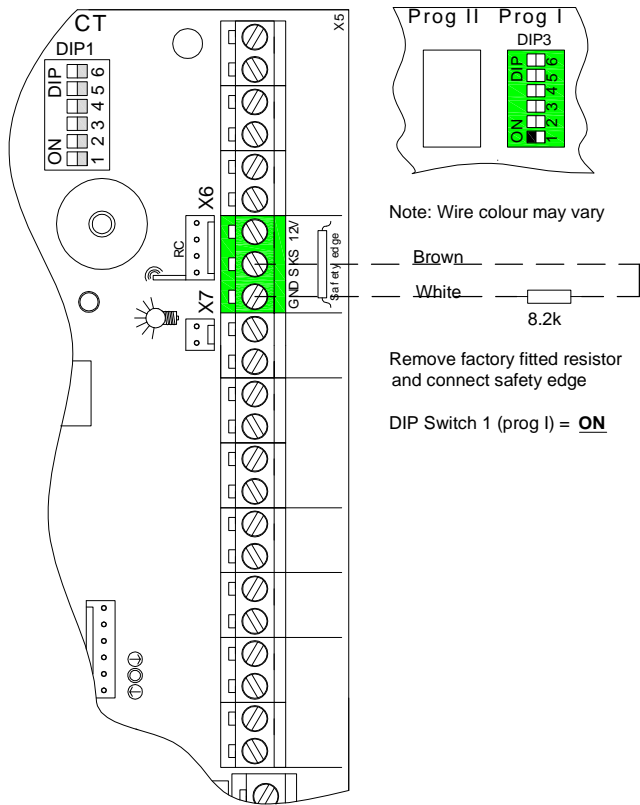

Optical Safety Edge

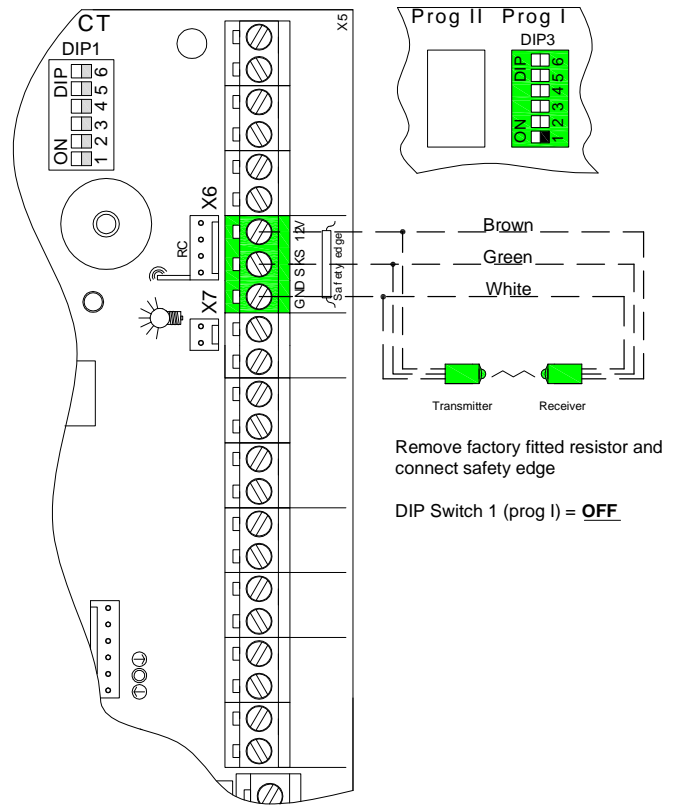

Pneumatic Safety Edge

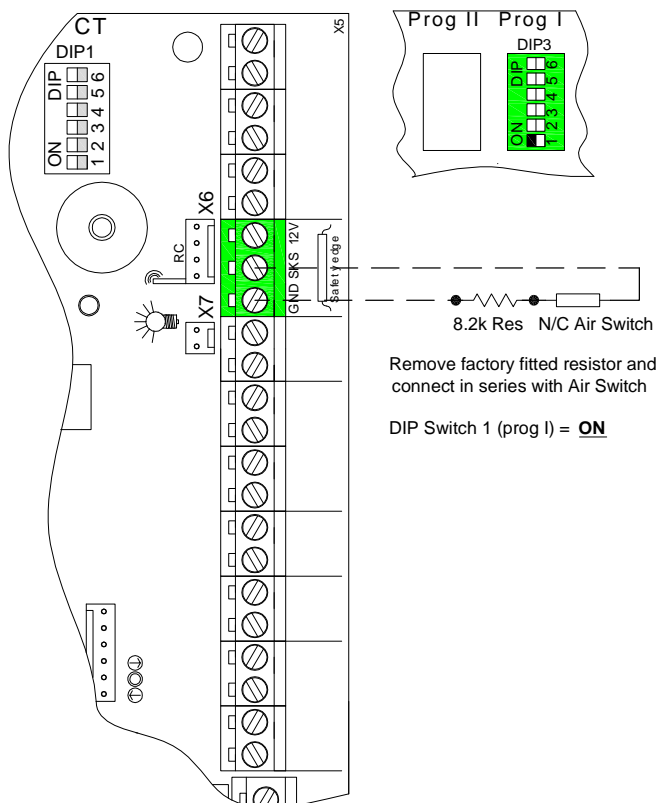

Photocell (reflective)

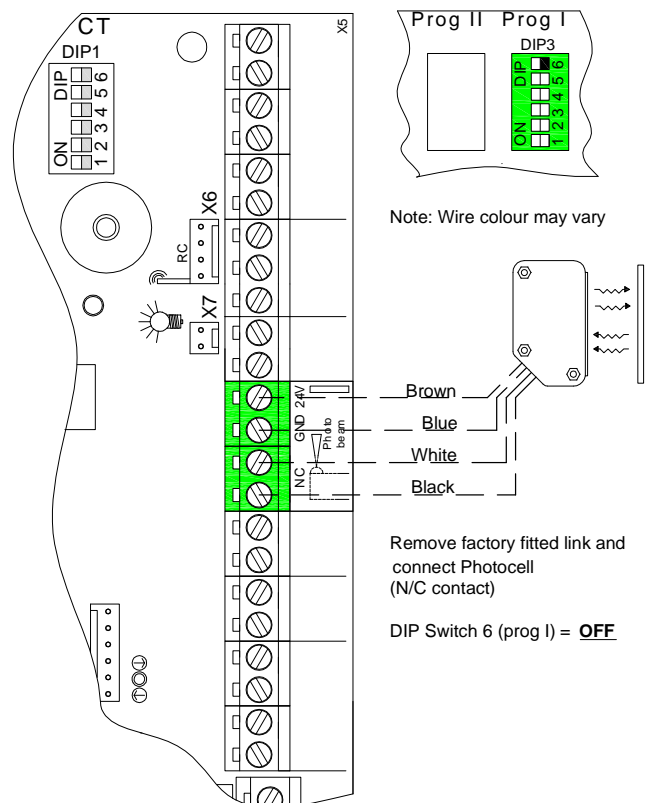

Pre-warning Light

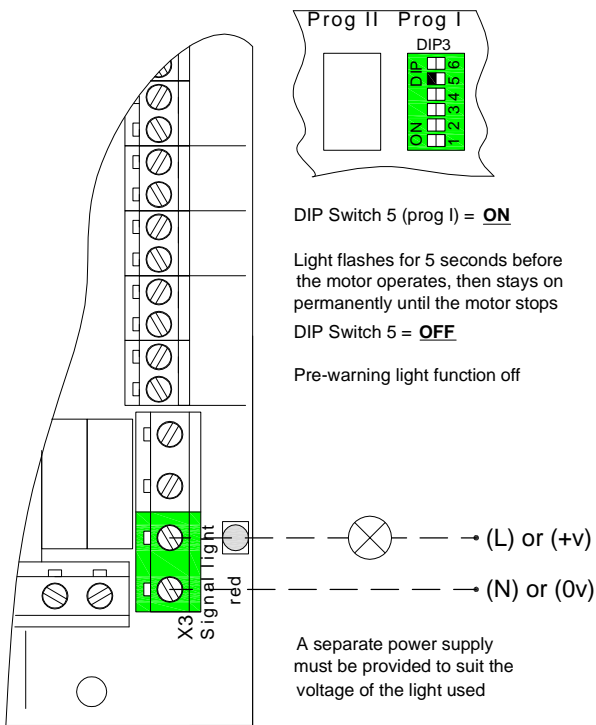

230V Courtesy Light

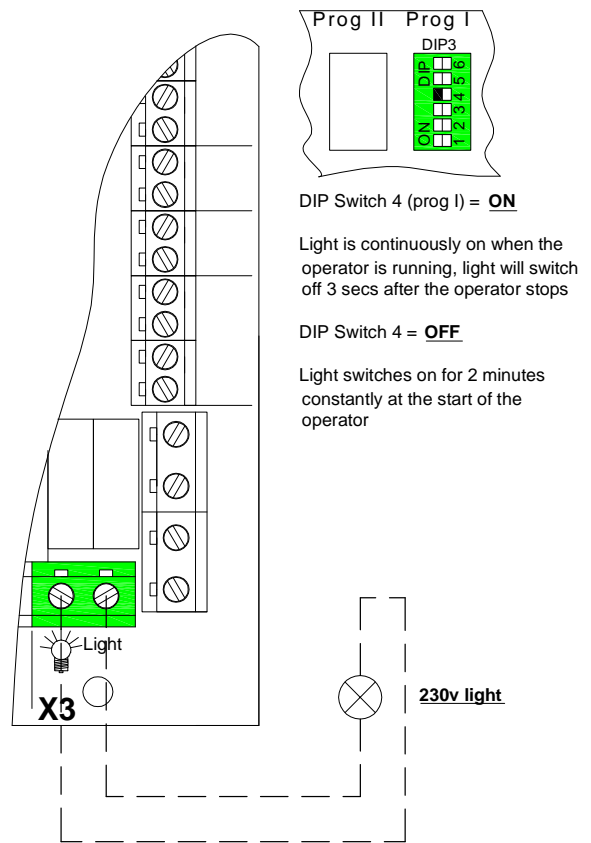

Red / Green Traffic Light

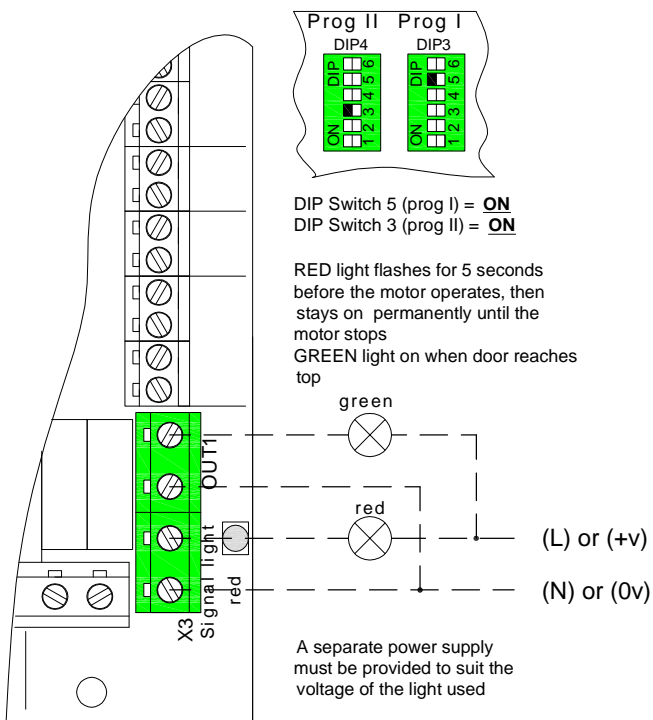

Radio Control (transmitter programming 20 max)

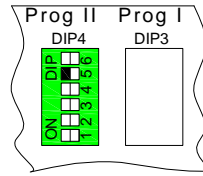
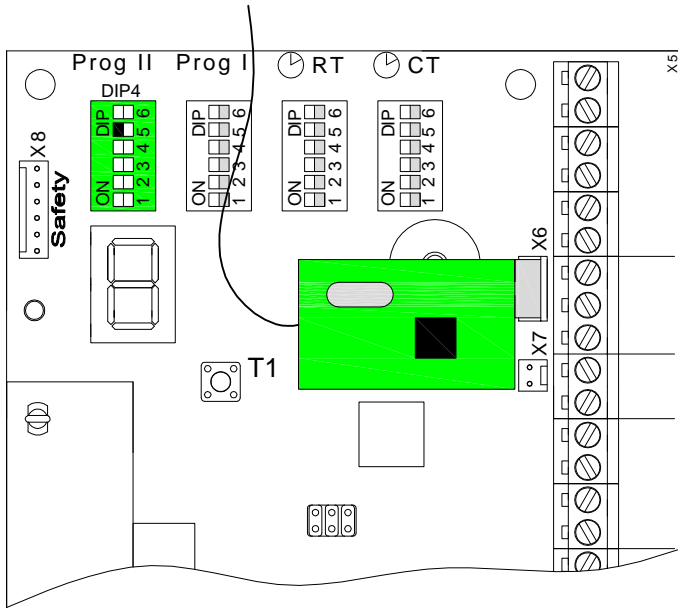

DIP Switch 5 (prog II) = **ON**

Plug in radio Receiver where shown
Turn DIP switch 5 to **ON**
The display now shows



Press and hold the button on the transmitter for 2 second, the DC2 will beep once



The transmitter is stored and the display will advance by one digit this is the next location to be used Repeat for each transmitter to a maximum of 20 handsets

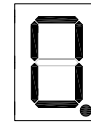

Number 10 transmitter location will be shown as thus

Once all transmitters have been entered DIP switch 5 must be switched off.

Radio Control (transmitter deleting)

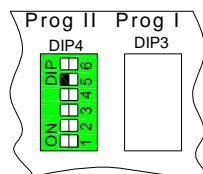
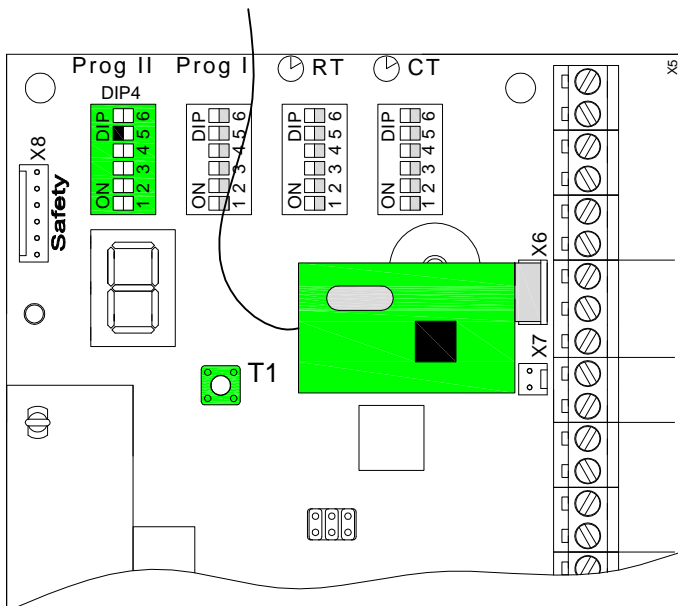

DIP Switch 5 (prog II) = **ON**

Turn DIP switch 5 to **ON**
The display now shows the last location to be used e.g.. 7







Using the **programming button T1** on the DC2 controller, scroll through the display to the location to be deleted

Press and hold the **programming button T1** the DC2 will beep twice this location is now empty

Repeat as necessary

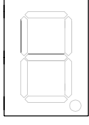
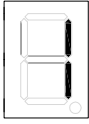
Once transmitters have been deleted DIP switch 5 must be switched off.

Trouble shooting - Common Faults

| Display | Fault | Check |
|--|--|---|
|  | Blank -No Power | Mains Fuse |
| | | PCB Fuse |
| | | Mains Power Supply |
|  | Emergency Stop Activated | Factory Fitted Link |
| | | Release E-Stop Button |
| | | |
|  | Safety Edge Activated | DIP Switch Position |
| | | Factory Fitted Resistor |
| | | Wiring or Loose Connections |
| | | Repalce sensors |
|  | Photocell Activated or open circuit | DIP Switch Position |
| | | Photocell alignment |
| | | Wiring or Loose Connections |
| | | Repalce photocell |
|  | Power Supply | Mains supply connected in wrong terminals (<i>and</i>) |
| | | Mains voltage is inconsistant and has risen above 245v |

| | | |
|-------|--|----------------------------------|
| Other | Radio Control opens door but will not close | DIP Switch Position |
| | | Photocell faulty or miss aligned |
| | | Wiring or Loose Connections |
| | | Faulty Safety Edge |

Technical data

| | |
|-------------------|---|
| Model | DC 2 - EURO delux |
| Supply Voltagel | 230VAC |
| Frequency | 50Hz |
| Protection class | IP54 |
| Outputs motor | 3x NO relay contact 230V / 5A |
| | 2x NO relay contact 230V / 2A |
| | 1x unregulated supply voltage 24V DC max 50mA |
| Wiring size (max) | 1.5mm ² max |
| Operature temp | -10°C to +55°C |



THE HOME OF AUTOMATION

Roundthorne Industrial Estate

Ellard House, Floats Road

Manchester M23 9WB

Tel: 0161 945 4561

e-mail: technical@ellard.co.uk